



WS 5.4501 Workholding Systems MC-P

clamping against the fixed jaw, mechanically operated

jaw widths 40, 60, 100 and 125 mm



Advantages

- Patented segment design
- Compact design
- High precision and accuracy of the manufactured workpieces by high rigidity
- High zero-point stability
- Sturdy design and good swarf protection
- Large jaw openings
- Extensive range of jaws
- Clamping of raw and finished parts without retrofitting
- Easy to maintain

Description

Workholding systems of the MC-P series excel by a very compact design and their patented segment design.

Thanks to the adjusting spindle arranged in the upper part of the housing, deformation in the base during clamping is reduced to a minimum. Thus, a high rigidity of the workholding system is obtained.

The patented segment design ensures a high degree of precision and stability. The guiding clearance is reduced to nearly zero. All essential components are made of hardened steel.

The workholding systems MC-P 100/125 are already prepared for the use on zero point clamping systems. For this purpose, there are location threads for retractable nipples at the bottom side of the housing.

For workholding systems MC-P, a wide range of clamping jaws is available (see data sheet WS 5.450Z).

Customised versions

MC-P workholding systems can also be delivered as customised versions. For example in hydraulically-operated versions, other lengths or with individual mounting holes. Please contact us.

Consultation

Our experts will be pleased to advise you also on site, and work with you to find the optimum clamping solution.

Extensive information such as drawings and CAD models are available on request.

Technical data

Clamping principle: **clamping against the fixed jaw mechanically**
 Operation: with a torque wrench

MC-P 40

Jaw width: 40 mm
 Clamping force*: 7.5 kN at 23 Nm
 Clamping stroke: 20 mm
 Max. jaw opening: 6–79 mm

MC-P 60

Jaw width: 60 mm
 Clamping force*: 15 kN at 60 Nm
 Clamping stroke: 30 mm
 Max. jaw opening: 6–150 mm

MC-P 100

Jaw width: 100 mm
 Clamping force*: 25 kN at 90 Nm
 Clamping stroke: 50 mm
 Max. jaw opening: 6–204 mm

MC-P 125

Jaw width: 125 mm
 Clamping force*: 40 kN at 180 Nm
 Clamping stroke: 101 mm
 Max. jaw opening: 6–215 mm

Versions

Mechanically operated

The movable clamping jaw is displaced by a threaded spindle which is also used to build-up the clamping force.

A torque wrench is used for exact and reproducible clamping force adjustment.

Hydraulically operated

Hydraulically-operated versions are available on request.

Please contact us.

*Important note

The specified clamping forces apply to a clamping height (n) of 15 mm.

For higher clamping heights, the clamping forces are reduced.

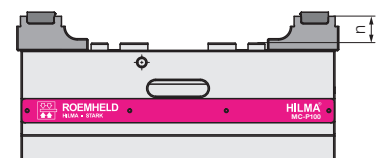

Application

The workholding systems MC-P are especially advantageous for 5-axis machining.

The compact design allows a good accessibility of the tools to the workpiece. Collision-free tool paths and a 5-sided workpiece machining can be achieved with short standard tools.

Due to the good swarf protection, workholding systems MC-P are particularly suitable for the use in pallet systems.

The high force and stability obviate the need for pre-stamping of the workpieces.

Accessories

- Clamping jaws and jaw inserts, accessories for mounting, positioning and operation see data sheet WS 5.450Z
- Rapid change block Quintus see data sheet WS 5.6150

Application example

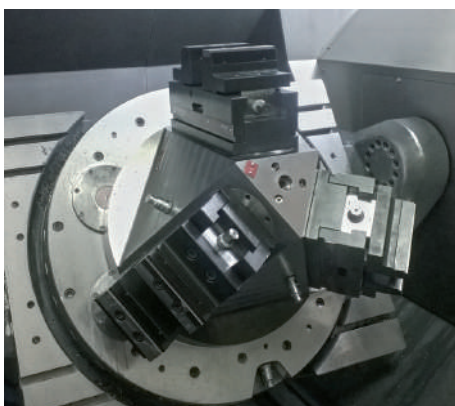

3 workholding systems MC-P in 3x120° arrangement on a 5-axis machining centre.

Technical data Dimensions

MC-P 40

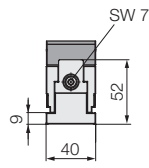
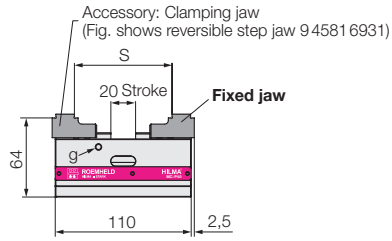

View from below

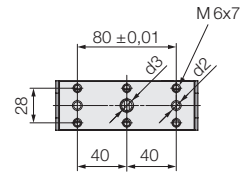

MC-P 60

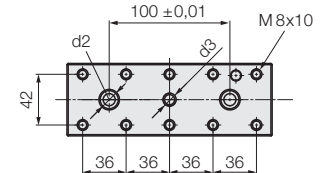
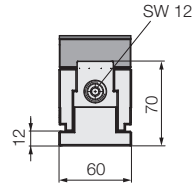
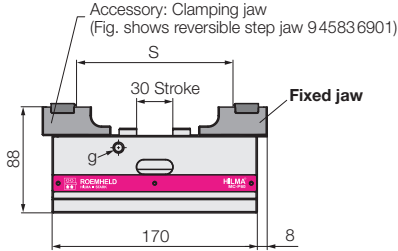

MC-P 100

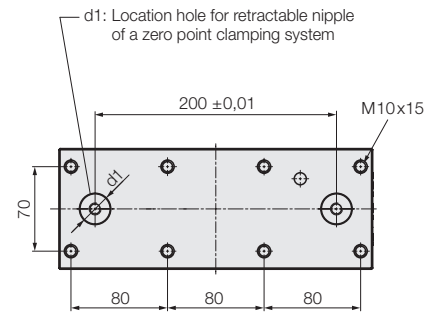
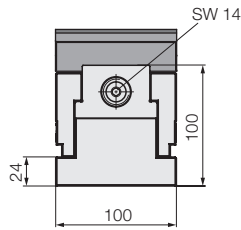
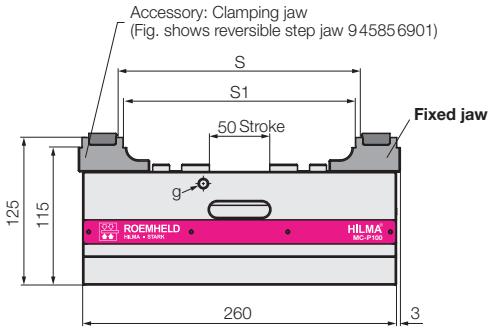

MC-P 125

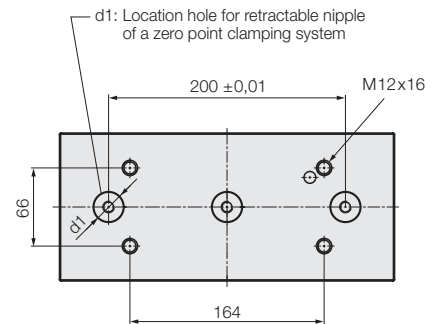
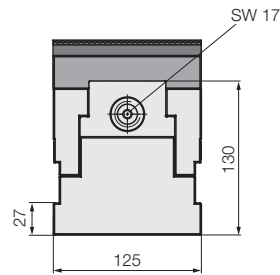
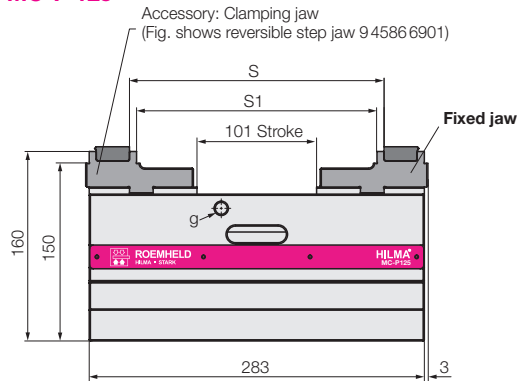

All dimensions in [mm]

Series		MC-P 40	MC-P 60	MC-P 100	MC-P 125
Clamping principle		fixed jaw	Fixed jaw	Fixed jaw	Fixed jaw
Operation		mechanical	mechanical	mechanical	mechanical
Clamping force / torque	[kN/Nm]	7.5/23	15/60	25/90	40/180
Repetitive clamping accuracy	[mm]	±0.01	±0.01	±0.01	±0.01
S*	[mm]	6–79	6–150	18–204	18–215
S1*	[mm]	–	–	6–192	6–203
d1	[mm]	–	–	25+0.01 x5 / M10x14	25+0.01 x5 / M10x18
d2	[mm]	6F7	10F7	–	–
d3	[mm]	M10x12	M10x11	–	–
g on both sides	[mm]	M5x6	M8x10	M8x14	M12x18
Weight without clamping jaws	[kg]	1.5	4.6	17.5	35.0
Part no. without clamping jaws		945810101	945830101	945850101	945860101

* depending on the used clamping jaw